

Research Article

Low-cost virtual instrumentation applied to geotechnical testing

Instrumentación virtual de bajo costo aplicado a pruebas de geotecnia

Dante Uriel Contreras-Ferreya¹: Universidad Michoacana de San Nicolás de Hidalgo, Mexico.

dante.contreras@umich.mx

Alondra Martínez-Rojas: Universidad Michoacana de San Nicolás de Hidalgo, Mexico.

alondra.martinez@umich.mx

Nelio Pastor-Gómez: Universidad Michoacana de San Nicolás de Hidalgo, Mexico.

npastor@umich.mx

Carlos Chávez-Negrete: Universidad Michoacana de San Nicolás de Hidalgo, Mexico.

cachavez@umich.mx

Receipt Date: 29/12/2024

Acceptance Date: 31/01/2025

Publication Date: 05/02/2025

How to cite the article

Contreras-Ferreya, D. U., Martínez-Rojas, A., Pastor-Gómez, N., & Chávez-Negrete, C. (2025). Low-cost virtual instrumentation applied to geotechnical testing [Instrumentación virtual de bajo costo aplicado a pruebas de geotecnia]. *European Public & Social Innovation Review*, 10, 01-17. <https://doi.org/10.31637/epsir-2025-1234>

Abstract

Introduction: In many of the current geotechnical tests, there is a need to improve data acquisition protocols, in addition to optimizing test procedures. The present work proposes the evaluation of 3 conventional sensors in geotechnical tests. **Methodology:** The devices used were an S3C DC-DC linear variable differential transformer, the HC-SR04 ultrasonic distance sensor, and the SKU:SEN0193 capacitive soil moisture sensor. The general methodology consisted of the development of the communication protocol, interface, and display of readings for each device. Subsequently, the calibration and precision level of each sensor was obtained. **Results:** The precision and reliability of the sensors were expressed according to the linear fit, obtaining R2 correlation values for all equipment. **Discussion:** The implemented systems allowed the detection of significant changes or trends in the behavior

¹ **Corresponding autor.** Dante Uriel Contreras-Ferreya. Universidad Michoacana de San Nicolás de Hidalgo, (Mexico).

of the materials, obtaining satisfactory performances in most of the sensors, except for the moisture sensor SKU:SEN0193, which registered low precision. **Conclusions:** The use of sensors offers an alternative to improve some of the typical geotechnical tests. However, it is important to mention that a particular calibration must be carried out for each sensor to be used.

Keywords: Instrumentation; geotechnics; Arduino; sensors; low cost; sampling; innovation; development; calibration; precision.

Resumen

Introducción: En muchas de las pruebas geotécnicas actuales, se tiene la necesidad de mejorar los protocolos de adquisición de datos, además de optimizar los procedimientos de prueba. El presente trabajo plantea la evaluación de 3 sensores convencionales en pruebas geotécnicas. **Metodología:** Los dispositivos utilizados fueron un transductor de desplazamiento lineal variable S3C DC-DC, el sensor ultrasónico de distancia HC-SR04 y el sensor de humedad capacitivo SKU:SEN0193. La metodología general consistió en el desarrollo del protocolo de comunicación, interfaz y despliegue de lecturas para cada equipo. Posteriormente, se obtuvo la calibración y el nivel de precisión de cada sensor. **Resultados:** La precisión y confiabilidad de los sensores se expresaron de acuerdo al ajuste lineal, obteniendo valores de correlación R^2 para todos los equipos. **Discusión:** Los sistemas implementados permitieron detectar cambios o tendencias significativas en el comportamiento de los materiales, obteniendo desempeños satisfactorios en la mayoría de los sensores, excepto en el sensor de humedad SKU:SEN0193, el cual registró una baja precisión. **Conclusiones:** El uso de sensores ofrece una alternativa para mejorar algunas de las pruebas geotecnias típicas. Sin embargo, es importante mencionar que se debe llevar a cabo una calibración particular para cada sensor a utilizar.

Palabras clave: Instrumentación; geotecnia; Arduino; sensores; bajo costo; muestreo; innovación; desarrollo; calibración; precisión.

1. Introduction

One of the most essential aspects of geotechnical engineering is the determination of the properties of soils, such as particle size, water content, shear strength, permeability, and load-bearing capacity (Das, 2009). These properties are commonly assessed by laboratory testing or through in situ determination. Therefore, it is essential to have adequate and precise geotechnical testing protocols in order to obtain an accurate characterization of the materials.

In the past, most geotechnical measurement equipment followed an analog or mechanical methodology, where the users had to visually read the lectures on the equipment and manually record the data throughout the test. This situation was prone to operator inaccuracies and not having good repeatability among different users. Furthermore, the data acquisition process could be considered tedious, specifically in lengthy tests (consolidation tests).

In this work, three different testing procedures were improved by using electronic sensors. The sensors used were the linear variable distance transducer (S3C DC-DC), the ultrasonic distance module (HC-SR04), and the soil moisture sensor (SKU:SEN0193). These sensors were utilized in a unidimensional consolidation test, an infiltration test, and Proctor compaction tests. The principle behind each testing procedure is discussed in the following sections.

1.1. Testing principles

1.1.1. Infiltration tests

Most geotechnical materials are permeable to some extent, due to the presence of interconnected voids through which water can access (Das, 2009). Such permeability is essential to measure since the excess of water affects the behavior of any geotechnical material. For example, in granular material, higher water contents generate a decrease in the resilient modulus (Ekbald and Isacsson, 2006). In asphalt pavements, when water gets in the asphalt mix layer, it increases the possibility of cracking (Kringos et al., 2008).

A laboratory or in-situ determination is performed to evaluate the water quantity that enters a soil mass. For a constant head methodology, it is necessary to measure how much water volume enters a determined surface area (Cooley 1999). The ASTM C1701 (ASTM, 2017) suggests a field infiltrometer following a said hydraulic principle, consisting of a 300 mm steel ring, which is positioned and fixed on the surface to measure.

To measure the surface infiltration, water is added inside the ring, keeping its level between two inner marks (10-15 mm), and recording how much water is needed to maintain the level. The infiltration rate is obtained by dividing the required water volume throughout the test by the ring's surface area. This process may be easy in terms of execution but is tiresome and prone to mistakes by the operators since the operator must be entirely focused on keeping the water level in the ring.

1.1.2. Proctor compaction test

Compaction is the densification of material, eliminating the air inside the mass by mechanical energy. One key aspect of the compaction process is the water content, which acts as a lubricant or softening agent, attaining a densely packed soil particle arrangement. However, beyond a certain water content, water begins to fill the space that would have been occupied by soil particles (Das, 2009). Therefore, it is important to measure the water content of a mass that will be compacted.

In Proctor standard compaction tests, soil with determined initial water content is placed in 3 layers inside a steel mold and compacted with 25 blows per layer using a 5,5-pound hammer. Then, knowing the volume of the mold, the specimen weight is recorded, and along with the measured water content of the sample, the dry unit weight is obtained. This process is repeated, increasing the water content of the soil until the maximum dry unit weight value is achieved (ASTM, 2012).

As mentioned, a water content determination must be performed in each compaction process. This water content assessment is commonly done using a gravimetric technique, recording the wet and dry mass of the soil sample. To obtain the dry mass, the wet soil must be placed in an oven for up to 16 hours or until no mass change is perceived (ASTM, 2019). Therefore, this procedure is time-consuming and does not allow to obtain dry unit weights immediately.

1.1.3. Consolidation test

When soils are subjected to stress, deformations occur. Increasing the load generates a downward vertical movement, allowing the soil to consolidate; this process is known as soil consolidation (Holtz, Kovacs, & Sheahan, 1981).

The one-dimensional soil consolidation test estimates how the soil will settle due to the application of a constant load and free drainage, which is essential to predict the possible displacements of any structure and improve the proper foundation design. For analytical purposes, consolidation under load as a function of time can be divided into three stages: initial compression, primary consolidation, and secondary consolidation. Defining the magnitude of primary consolidation and the primary consolidation-time curve, along with the derived parameters, are the main objectives of a laboratory consolidation test (Head & Epps, 2011).

The test method is described in ASTM D2435 M-11 (2020), “Standard Test Methods for One-Dimensional Consolidation Properties of Soils by Incremental Loading”. The test is carried out by applying a sequence of four to eight vertical loads to a laterally confined specimen. Vertical compression is observed and recorded manually over a period of time, usually 24 hours, for each load increment. The most commonly used equipment is the lever consolidometer, where the load is applied by a lever arm that holds plate weights and is, connected to a vertical displacement measurement device. In a conventional mechanical consolidometer, extended periods of time are required to perform the tests, since the data is captured manually, thus making it necessary for the operator to take constant measures throughout the entire test execution.

1.2. Instrumentation overview

Instrumentation combines sensing, hardware, and software technologies with computational technologies to create solutions to user-defined problems (Obrenovic et al., 2006; SaravanaKumar et al., 2009). Currently, instrumentation has a wide range of applications, from engineering to medicine, allowing monitoring and controlling various parameters in real-time and optimizing processes. Electronic sensors can measure physical variables (such as flow, distance, and temperature) and convert them to an electrical signal, which is useful for executing experiments and gathering accurate and reliable data.

Therefore, this research aimed to optimize the test procedures by reconditioning some equipment, improving the measurement and capture of data through electronic sensors, and reducing the influence and time invested by the operator. This process was achieved through semi-automatic instrumentation of low cost, based on the programming language interface “Python” and “LabVIEW” from National Instruments, using Arduino UNO data acquisition device; which is a low-cost plate (Motahhir et al. 2017), where measurements can be acquired directly in real-time.

2. Methodology

2.1. Sensors measuring principles

2.1.1. HC-SR04 sensor

The HC-SR04 is a low-cost sensor to measure distance using ultrasonic waves. Its working principle is divided into two parts: first, the sensor generates a 40 kHz ultrasonic pulse; then, the pulse intercepts the object whose distance is desired to measure. Afterward, the pulse bounces back from the object and is caught by the sensor. The distance of the object is obtained using the velocity of the ultrasonic pulse and the time-lapse that takes the wave to reach the object and back (Zhmud et al. 2018). According to the manufacturer, the HC-SR04 covers a measuring distance range of 2 to 40 cm, with an accuracy of up to 3 mm.

It has four output pins: a VCC pin connected to the power supply (5V), a trigger, an echo pin that sends and receives the pulse, respectively, and a Gnd pin connected to the ground of the circuit. Figure 1 represents the measuring principle of the sensor.

Figure 1.

Measuring principle of the HC-SR04 sensor

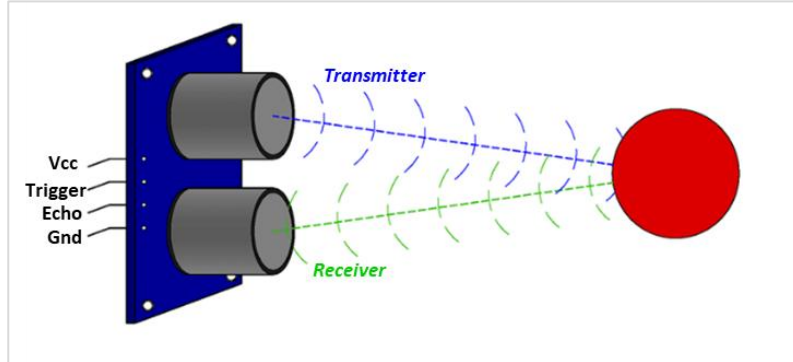

Source: Own elaboration (2024).

2.1.2. *Capacitive soil moisture sensor (SKU:SEN0193)*

The SKU: SEN0193 is an analog sensor that measures the capacitance of a media, i.e., how much electrical charge the media can store for a given electrical potential (Ida, 2015). Knowing that the water content of a mass is related to its electrical properties (since the water acts as a conductor of electricity), the capacitance of a soil gives an indirect measure of its water content. As a result, this sensor output voltage changes related to the water content of the soil sample.

Physically, the sensor probes are covered with anti-corrosion material to improve its durability (Figure 2). Regarding its configuration, it has a 3-pin configuration: an analog output pin, that sends the data from the sensor, a VCC pin where the sensor is powered with 3,3 to 5 V, and a Gnd pin. It is worth mentioning that the SKU:SEN0193 has been used by other authors, specifically in agriculture and planting, with good accuracy in such applications (Kulmany et al 2022, Muzdrikah et al 2018).

Figure 2.

Schematic representation of the components SKU:SEN0193 sensor

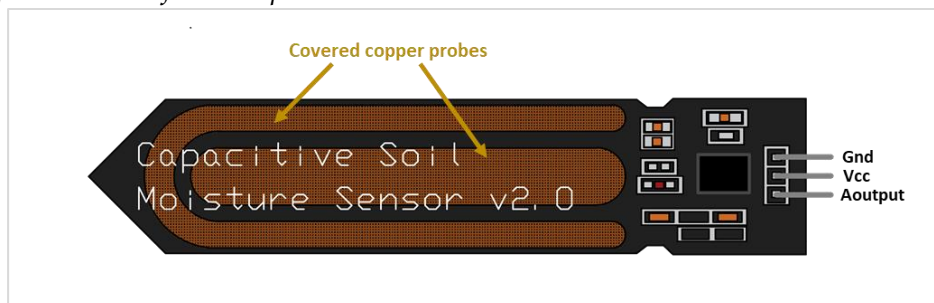

Source: Own elaboration (2024).

2.1.3. Sensor Linear Variable Differential Transformer (S3C DC-DC)

The Honeywell model S3C DC-DC miniature Linear Variable Differential Transformer (LVDT) has a total stroke range of $\pm 2,54\text{mm}$ to $10,16\text{mm}$ with output of $\pm 5\text{VDC}$ or 0 to 10VDC , that operates with a dual power supply of $\pm 12\text{VDC}$ to $\pm 20\text{VDC}$ or a single power supply of 24 to 40VDC ., with 6ft long shielded multiconductor cable (Honeywell, 2009). The sensor uses a contact profilometer, whose objective is to convert the displacement variations of a rod into voltage variations, through the displacement of the core coupled to the rod through a coil (Uribe et al., 2014). Figure 3 shows the diagram of the LVDT sensor with its color code in a single input configuration.

Figure 3.

Diagram of the LVDT sensor with its color code

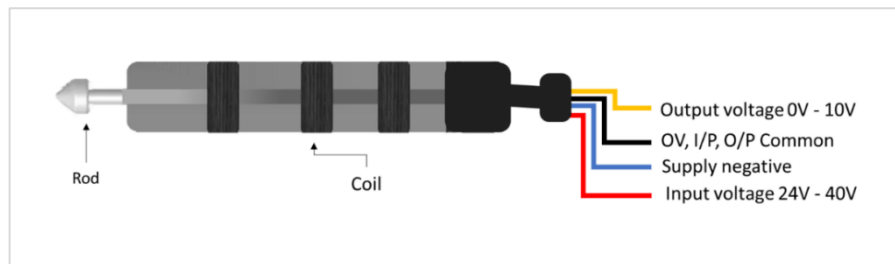

Source: Own elaboration (2024).

2.2. Sensor installation, wiring, and communication

2.2.1. HC-SR04 ultrasonic sensor

As previously stated, water volume must be measured to obtain surface infiltration using a constant head principle. This context leads to using an external container that supplies water to the infiltration ring where the water is infiltrated within. One type of container suitable for this application is a Mariotte bottle. This hydraulic device is used to supply water at a constant rate and pressure, maintaining a constant water level at a predetermined height (Kires, 2006). However, this type of container must be entirely sealed in order to function properly.

Nowadays, many sensors in the market directly measure the water volume inside a container, adopting different principles (floating, optical, radar, etc.), nonetheless, many of them primarily measure the water level of the container, obtaining the water volume by multiplying such height by the cross-sectional area of the container. Following this concept, the HC-SR04 was implemented under the top of the Mariotte bottle, measuring the distance between the top and the water level, and detecting changes in the water content inside due to the water infiltration. Figure 4 shows the HC-SR04 sensor placed on the Mariotte bottle.

Figure 4.

a) HC-SR04 installation in the Mariotte bottle; b) Measuring range of the water level by the sensor

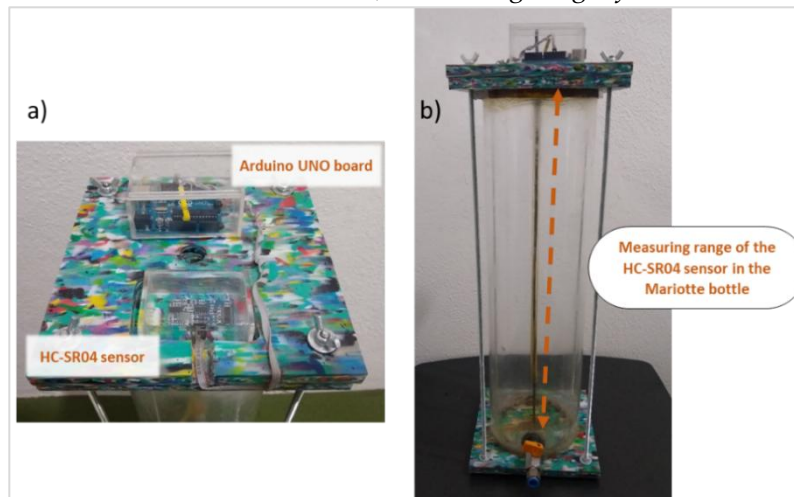

Source: Own elaboration (2024).

To increase the portability of the device, an Arduino UNO board was also mounted on top of the Mariotte bottle, having the sensor directly connected to the board. The Arduino UNO supplied the voltage to the sensor and enabled the data transmission. Once the sensor was connected to the Arduino board, the sensing and communication protocol was established using Python programming language, specifically the PySerial package (Van Rossum, G. & Drake Jr, F. L., 1995).

Given that this specific sensor is relatively common, several online codes can be found that directly convert the voltage output to actual distance. Following one example of these codes, the algorithm was complemented, adopting a sample rate of 5 readings per second. Although this sample rate is not considered remarkably high, a fair amount of reading noise was observed. Therefore a moving average of every 3 seconds was applied to the algorithm, thus reducing the noise and obtaining appropriate readings.

2.2.2. Capacitive soil moisture sensor (SKU:SEN0193)

To determine the water content using the SKU:SEN0193, it must be in direct contact with the wet soil sample. When used in other circumstances where the soil is relatively loose, such as flower pots or directly in the field, the sensor is inserted gently into the soil. However, in compaction tests, the soil tends to be fairly compact, hindering the sensor placement. Therefore, this sensor must be integrated into the soil specimen when compacting it.

Following this principle, the sensor was laterally introduced between the first and second layers during the Proctor compaction process, since the first layer serves as a flat support layer for the sensor (Figure 5). This procedure accomplished an effective contact between the sensor and the soil. It is worth mentioning that the exposed electrical components of the sensor were covered using shrink tubing to avoid any possible damage related to the sensor handling. Furthermore, the tested soil corresponds to a low-plasticity sand-silt mixture.

Figure 5.

a) Insertion of the SKU:SEN0193 into the Proctor mold; b) Encasing of the sensor between the compacted soil layers

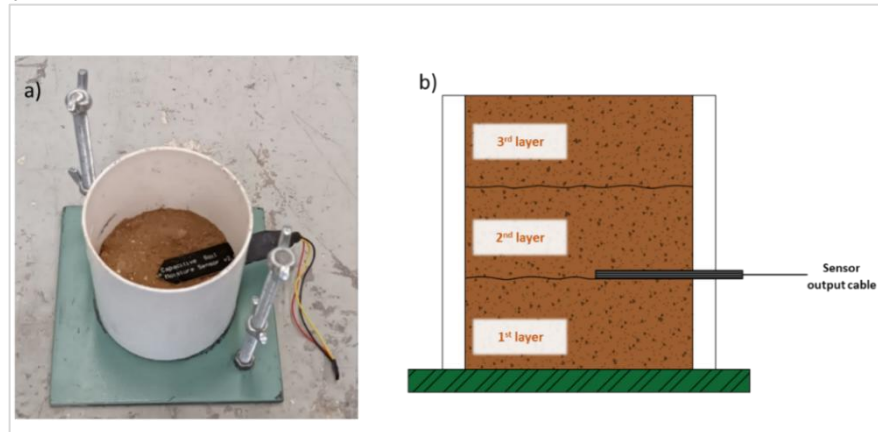

Source: Own elaboration (2024).

Once the soil was placed, it was connected to an Arduino UNO board to begin the data acquisition. Theoretically, the soil sample to measure is homogenous and contains the same water content. Therefore, there should not be fluctuations in the sensor readings. Hence, a low sample rate was defined as one lecture every 5 seconds, and no signal filter was considered given such small sample rate, and the low amount of signal noise observed in the prototype test runs.

Once again, the lectures were displayed using Python, plotting the sensor readings against time. In some cases, the lectures quickly stabilized to a constant value. However, this process took a lot longer in some other cases (up to 40 minutes), but no pattern was found regarding this behavior.

2.2.3. Sensor LVDT S3C DC-DC

While this sensor may be a little more expensive than the other sensors, its connection will follow the low-cost connection concept, using once again an Arduino UNO board. However, since the output voltage of the sensor is from 0V to 10V, and the Arduino UNO board has a voltage input from 0V to 5V, it was necessary to implement a voltage divider. The voltage divider is a passive linear circuit that produces an output voltage fractional of the input voltage. Voltage division is the result of distributing the input voltage between the components of the divider (Zetina & Zetina, 1999).

This was done with two resistors connected in series, with the input voltage applied through a pair of resistors and the output voltage resulting from the connection between them. To calculate the output voltage, equation (1) was used, where the output value is equivalent to the input voltage scaled by the ratio of the resistances: the lower resistance divided by the sum of the two resistances, based on the unknown current according to Ohm's Law, and starting from the additive property of series resistances.

$$V_{out} = \frac{V_{in}(R_2)}{(R_1 + R_2)} \quad (1)$$

Where V_{out} is the output voltage [V], V_{in} is the input voltage [V], and R_1 and R_2 represent the resistances connected in series, upper and lower respectively [Ω]. For this particular case, the input voltage equals 10V, and the resistors used were of 5K Ω , obtaining an output voltage of 5V. Figure 6 shows the voltage divider diagram used.

Figure 7 represents the complete wiring diagram, where the yellow cable is connected to the Arduino UNO through the analog input channel A0, the black cable to the corresponding ground pin (GND), the red cable to the positive power supply, and the blue to the negative, passing the yellow cable previously through the voltage divider. The power supply used was a simple 24 V.

Figure 6.

Voltage divider diagram

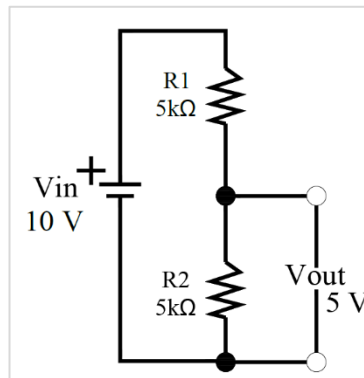

Source: Own elaboration (2024).

The communication protocol was established through LabVIEW software, which contains an interface to communicate with common embedded platforms, whose name is LINX. In this case, said interface was used to connect with Arduino. It is important to keep in mind that each block used in the Arduino package installed in LabVIEW represents an actual function of the Arduino language, and each entry in the block in LabVIEW represents the input parameters for said function. A program was developed for readings and time recording. The front panel of the program is shown in Figure 8. The program outputs a .xls extension file with the tabulated time-strain data, which are also plotted in real-time in the typical consolidation graph.

Figure 7.

LVDT sensor wiring diagram

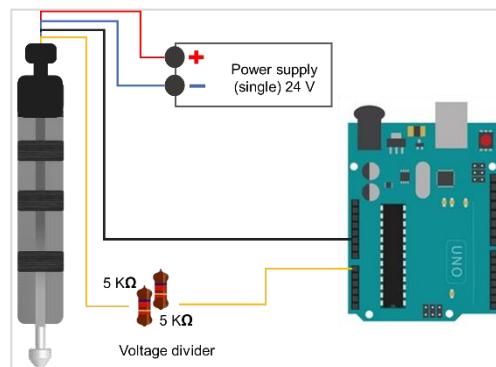

Source: Own elaboration (2024).

Figure 8.

Program in LabVIEW

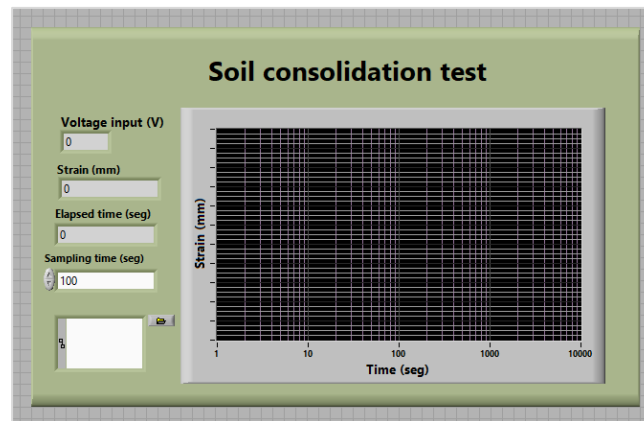

Source: Own elaboration (2024).

3. Results and discussion

The results related to the accuracies of the sensors are presented next. Each sensor was calibrated through several readings, comparing the voltage output of the sensor to an actual measurement of the variable using a standard or common technique, changing the data measured. Plotting those two values, a calibration curve is obtained for each sensor.

Typically, a linear regression analysis is performed for the data, computing a correlation equation that serves as the calibration for each specimen. Furthermore, the Pearson squared correlation coefficient (R^2) was calculated for each data set to determine how strong the linear correlation in the data is. In practical terms, a correlation coefficient close to 1 is considered good, implying a high accuracy and reliability in the sensor readings.

Since the initial algorithm for this sensor already outputs the distance from the sensor to the water level, the calibration curve does not consider the voltage output of the sensor. For the calibration, the distance measured by the sensor was compared to an actual measurement performed by measuring tape. The resulting data set is displayed in Figure 9, which includes 30 different readings, where the mean error between the sensor readings and the real distances was 4 mm, 1 mm above the value stated by the manufacturer. However, as presented in Figure 9, the correlation coefficient equals 0,9899, a pretty close value to 1. Thus, the HC-SR04 sensor is regarded as suitable for use in a Mariotte bottle to register its water level.

Figure 9.

Experimental results of the HC-SR04 sensor

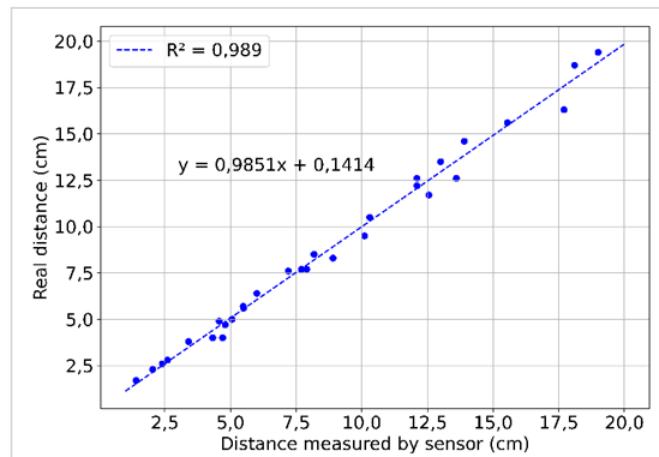

Source: Own elaboration (2024).

Figure 10 contains the result obtained in the SKU:SEN0193 sensor calibration process, where 22 specimen samples were compacted with varying volumetric water contents from 17 to 42%. As shown, the voltage values registered by the sensor only fluctuate between 0,9, and 1 volts, despite the fact that the sensor could theoretically vary from 0 to 5 volts since that range corresponds to its powering voltage.

Hence, a high slope is observed in the calibration equation, inferring a high water content variability in relation to the output voltage. These irregularities are reflected in the correlation coefficient calculated of 0,605, which represents a weak correlation between the lectures and, subsequently, the low accuracy of the sensor in this type of compaction test.

Figure 10.

Experimental results of the SKU:SEN0193 sensor

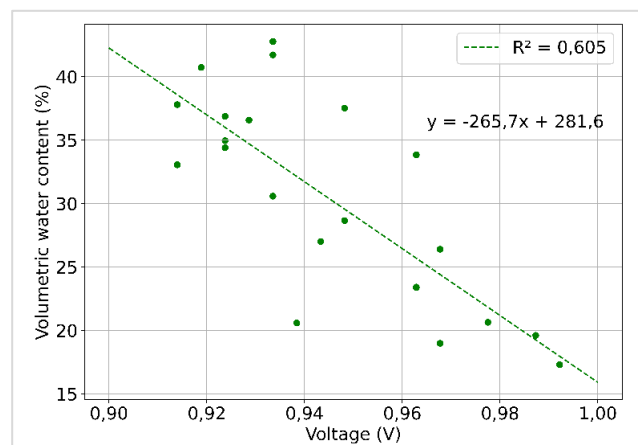

Source: Own elaboration (2024).

For the calibration of the LVDT sensor, a series of points were employed to adjust a straight line that described the relationship between electrical and physical values. For this purpose, ten displacement values were measured with a high-accuracy dial indicator (mm), compared to the corresponding voltage signal delivered by the sensor (Figure 11).

The resulting equation $y=2,069563x+1,468202$ was adjusted to a linear regression with a correlation coefficient (R2) of 0,99. Figure 12 shows the calibration curve obtained. As shown in the figure, the voltage detected by the sensor covers the entire 5-volt range of the Arduino Uno input channel, which is correlated to the sensor's 12 mm measuring distance range. Based on the calibration results of the LVDT sensor, it is possible to conclude that the adjustment of the model is highly precise since the value of R2 is very close to 1.

Figure 11.

LVDT sensor calibration



Source: Own elaboration (2024).

Figure 12.

Experimental results of the LVDT sensor

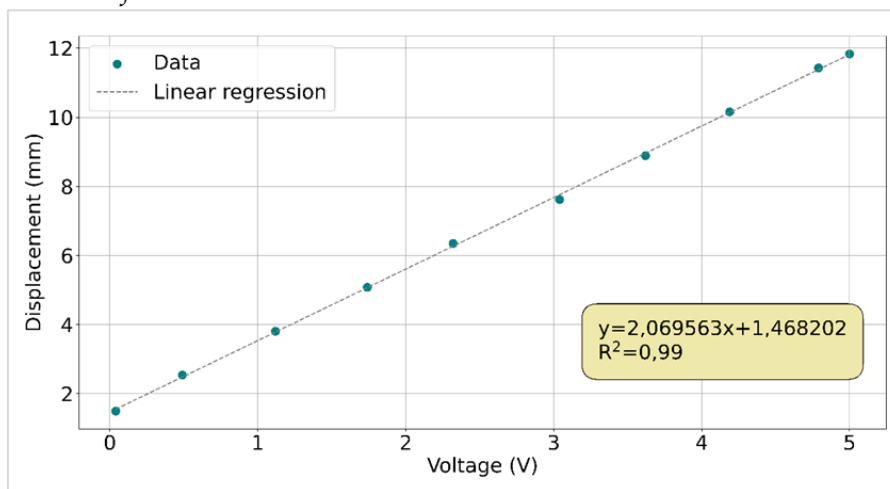

Source: Own elaboration (2024).

4. Conclusions

Geotechnical characterization tests allow to identify and estimate the way soil behaves under different scenarios, which is essential to predict deformations and, in general, civil engineering applications. However, many times, the equipment available to carry out the tests is out of use, they are complicated at the laboratory level, or the equipment cost is very high.

One way to restore dated equipment and extend its useful life by maximizing its performance (in the case of an oedometer) is to modify it using electronic instruments. By equipment reconditioning through instrumentation, modifications or updates can be made according to the requirements. In this sense, the work presented in this research aimed to implement the instrumentation in laboratory tests. With the advances in electronic sensors, it is expected that the testing procedures will be completely automated, providing better results and creating increasingly functional tools for the development of science.

This research studied the applicability and accuracy of three sensors in a geotechnical testing context, specifically in consolidation, infiltration, and compaction tests. The results demonstrated that not all the sensors render suitable results for the accuracy needed in these tests. The S3C DC-DC sensor proved to be a great addition to the consolidation tests, particularly in the dated equipment where the vertical displacement of the soil samples is still measured by dial indicators that require constant assessing by the operator.

However, it should be noted that the connection of this sensor is not as straightforward as it is in other simpler sensors since it demands a higher powering voltage (at least 24 V) and its output voltage ranges up to 10 V. Therefore, it is suggested to follow the considerations described in this work in order to connect this sensor to low-cost microcontroller boards (e.g., Arduino UNO).

Similarly to the S3C DC-DC, the HC-SR04 offers high reliability when applied to the context of the Mariotte bottle used for the infiltration test. With this innovation of the instrumented Mariotte bottle, not only the manual supply of water to the infiltration ring is eliminated, but its measuring becomes easier since the sensor records all changes in the water level, which translates to the volume provided by the bottle. Consequently, this sensor could be used in any liquid container with a top to measure its volume or water level. Nonetheless, the observed 4 mm average error in the water level should be considered for future applications.

While the S3C DC-DC and the HC-SR04 yielded excellent correlation and precision in their respective applications, the SKU:SEN0193 could not be regarded as a dependable sensor since its small correlation coefficient. Based on the results, the sensor could be used only to determine if the soil compacted is in a wet or dry state, but it does not provide an accurate volumetric water content in terms of percentage. Therefore, another and better sensor must be used for the Proctor compaction test to obtain reliable and precise results.

6. References

- ASTM D2435 M-11. (2020). *Standard Test Methods for One-Dimensional Consolidation Properties of Soils Using Incremental Loading*. United States: American Society for Testing and Materials. https://doi.org/10.1520/D2435_D2435M-11R20
- ASTM D2216. (2019). *Standard Test Methods for Laboratory Determination of Water (Moisture) Content of Soil and Rock by Mass*. PA, United States: American Society for Testing and Materials. <https://doi.org/10.1520/D2216-19>
- ASTM D698. (2012). *Standard Test Methods for Laboratory Compaction Characteristics of Soil using Standard Effort (12,400 ft-lbf/ft³ (600 kN-m/m³))*. PA, United States: American Society for Testing and Materials. <https://doi.org/10.1520/D0698-12R21>
- ASTM C-1701. (2023). *Standard test method for infiltration rate of in place pervious concrete*. United States: American Society for Testing and Materials. https://doi.org/10.1520/C1701_C1701M-17AR23
- Cooley, L. A. (1999). Permeability of superpave mixtures: evaluation of field permeameters. *Auburn, AL: National Center for Asphalt Technology (NCAT)*, 99-1. <https://rosap.ntl.bts.gov/view/dot/13975>
- Das, B. M. (2009). *Principles of Geotechnical Engineering*. Cengage Learning.
- Ekblad, J., & Isacsson, U. (2006). Influence of water on resilient properties of coarse granular materials. *Road Materials and Pavement Design*, 7(3), 369-404. <https://doi.org/10.1080/14680629.2006.9690043>
- Head, K. H., & Epps, R. J. (2011). *Manual of Soil Laboratory Testing, Volume 2: Permeability, Shear Strength and Compressibility tests*. (3rd Edition), Whittles Publishing, Dunbeath, UK.
- Holtz, R. D., Kovacs, W. D., & Sheahan, T. C. (1981). *An introduction to geotechnical engineering*, 733. Englewood Cliffs: Prentice-Hall.
- Honeywell. (2009). *Model S3C DC-DC. Miniature Displacement Transducer*. 008757-2-EN IL50 GLO.
- Kireš, M. (2006). Mariotte bottle with side openings. *The Physics Teacher*, 44(6), 388-389. <https://acortar.link/nlbq18>
- Kulmány, I. M., Bede-Fazekas, Á., Beslin, A., Giczi, Z., Milics, G., Kovács, B., Kovácd, M., Ambrus, B., Bede, L., & Vona, V. (2022). Calibration of an Arduino-based low-cost capacitive soil moisture sensor for smart agriculture. *Journal of Hydrology and Hydromechanics*, 70(3), 330-340. <https://doi.org/10.2478/johh-2022-0014>
- Motahhir, S., Chalh, A., El Ghzizal, A., Sebti, S., & Derouich, A. (2017). Modeling of photovoltaic panel by using proteus. *Journal of Engineering Science and Technology Review*, 10, 8-13. <https://doi.org/10.25103/jestr.102.02>

- Muzdrikah, F. S., Nuha, M. S., & Rizqi, F. A. (2018). *Calibration of capacitive soil moisture sensor (SKU: SEN0193)*. In 2018 4th International Conference on Science and Technology (ICST) (pp. 1-6). IEEE. <https://doi.org/10.1109/ICSTC.2018.8528624>
- Obrenovic, Ž., Starcevic, D., & Jovanov, E. (2006). *Virtual Instrumentation*. Wiley Encyclopedia of Biomedical Engineering, Wiley. <https://obren.io/papers/virtualinstrumentation.pdf>
- Saravanakumar, G., Wahidabanu, R. S. D., & Nayak, C. G. (2009). Performance analysis of various Smith predictors for integrating processes with longer dead-time. *International Journal of Automation and Control*, 3(2-3), 248-263. <https://doi.org/10.1504/IJAAC.2009.025245>
- Uribe Martínez, J. M., Quintero Rodríguez, L. J., Tirado-Mejía, L., & Ibargüen, F. J. (2014). Acondicionamiento y digitalización de la señal de un LVDT para la medición del perfil de una superficie sólida: Acondicionamiento y Digitalización de un LVDT. *Revista De Investigaciones Universidad Del Quindío*, 25(1), 113-119. <https://doi.org/10.33975/riuq.vol25n1.160>
- Van Rossum, G., & Drake Jr, F. L. (1995). *Python reference manual*. Amsterdam: Centrum voor 354 Wiskunde & Informatica.
- Zetina, A., y Zetina, Á. (1999). *Electrónica básica*. Editorial Limusa.
- Zhmud, V. A., Kondratiev, N. O., Kuznetsov, K. A., Trubin, V. G., & Dimitrov, L. V. (2018). Application of ultrasonic sensor for measuring distances in robotics. *Journal of Physics: Conference Series*, 1015(3), p. 032189). IOP Publishing. <https://doi.org/10.1088/1742-6596/1015/3/032189>

AUTHORS CONTRIBUTIONS, FUNDING AND ACKNOWLEDGMENTS

Contributions of authors:

Conceptualization: Pastor-Gómez, Nelio; **Software:** Contreras-Ferreyra, Dante Uriel, & Martínez-Rojas, Alondra; **Validation:** Chávez-Negrete, Carlos, Contreras-Ferreyra, Dante Uriel, Martínez-Rojas, Alondra, & Pastor-Gómez, Nelio; **Formal analysis:** Chávez-Negrete, Carlos, & Pastor-Gómez, Nelio; **Data Curation:** Contreras-Ferreyra, Dante Uriel, & Martínez-Rojas, Alondra; **Writing-Preparation of the original draft:** Contreras-Ferreyra, Dante Uriel, & Martínez-Rojas, Alondra; **Writing-Review and Editing:** Chávez-Negrete, Carlos, Contreras-Ferreyra, Dante Uriel, Martínez-Rojas, Alondra, & Pastor-Gómez, Nelio; **Visualization:** Contreras-Ferreyra, Dante Uriel, & Martínez-Rojas, Alondra; **Supervision:** Chávez-Negrete, Carlos, & Pastor-Gómez, Nelio; **Project management:** Chávez-Negrete, Carlos, & Pastor-Gómez, Nelio; **All authors have read and agreed to the published version of the manuscript:** Chávez-Negrete, Carlos, Contreras-Ferreyra, Dante Uriel, Martínez-Rojas, Alondra, & Pastor-Gómez, Nelio.

Funding: This research was funded partially by the Coordinación de la Investigación Científica (CIC), of the Univesidad Michoacana de San Nicolás de Hidalgo.

Acknowledgments: The authors would like to thank the support from the Consejo Nacional de Humanidades, Ciencias y Tecnologías and the Faculty of Civil Engineering, of the Universidad Michoacana de San Nicolás de Hidalgo.

Conflict of interests: The authors declare that they have no conflicts of interests.

AUTHORS:

Dante Uriel Contreras-Ferreya

Universidad Michoacana de San Nicolás de Hidalgo, Mexico.

Dante Uriel Contreras-Ferreya is PhD student and professor at the Civil Engineering School of the Universidad Michoacana de San Nicolás de Hidalgo (UMSNH) in Morelia, México. He holds a Master's Degree in Transport Infrastructure from Universidad Michoacana de San Nicolás de Hidalgo. His research interest include laboratory characterization of soils, soil mechanics, pavement analysis, and instrumentation applied to geotechnical engineering.

dante.contreras@umich.mx

Orcid ID: <https://orcid.org/0009-0002-2266-7706>

Google Scholar: <https://scholar.google.com/citations?hl=es&user=nydCq-UAAAAJ>

Alondra Martínez-Rojas

Universidad Michoacana de San Nicolás de Hidalgo, Mexico.

Alondra Martínez-Rojas is PhD student and professor at the Civil Engineering School of the Universidad Michoacana de San Nicolás de Hidalgo (UMSNH) in Morelia, México. She holds a Master's Degree in Transport Infrastructure from Universidad Michoacana de San Nicolás de Hidalgo. Her research interest include laboratory characterization of soils and rock, soil mechanics and stabilization, topographic analysis, and instrumentation applied to geotechnical engineering.

alondra.martinez@umich.mx

Orcid ID: <https://orcid.org/0009-0006-5373-363X>

Google Scholar: <https://scholar.google.com/citations?user=1Gedm74AAAAJ&hl=es>

Nelio Pastor-Gómez

Universidad Michoacana de San Nicolás de Hidalgo, Mexico.

Nelio Pastor-Gómez is a professor and researcher at the Faculty of Civil Engineering of the Universidad Michoacana de San Nicolás de Hidalgo (UMSNH) in Morelia, Mexico. His research interest include Instrumentation, Virtual Instrumentation, Digital Signal Processing, and Mathematical Modeling. He holds a Ph D. In Electrical Engineering from UMSNH. He is currently a professor in the Master in Transport Infrastructure teaching the subjects Instrumentation and Statistics; in the degree in Civil Engineering, He teaches Programming and Numerical Methods at the Faculty of Civil Engineering of the UMSNH.

npastor@umich.mx

Orcid ID: <https://orcid.org/0000-0003-3293-672X>

Carlos Chávez-Negrete

Universidad Michoacana de San Nicolás de Hidalgo, Mexico.

Carlos Chávez-Negrete is a professor at the Civil Engineering School of the Universidad Michoacana de San Nicolás de Hidalgo (UMSNH) in Morelia, Mexico. He holds a Ph.D. in Geotechnical Engineering from Universitat Politècnica de Catalunya, in Spain. His research interest include laboratory characterization of soils and rocks, slope stability analysis, pavement analysis, and design, the development of numerical methods for geotechnical engineering, and unsaturated soil mechanics. Chávez-Negrete is currently a professor in the master's in transport infrastructure and the Ph.D. program in civil engineering in the (UMSNH).

cachavez@umich.mx

Orcid ID: <https://orcid.org/0000-0002-3932-6943>

Google Scholar: <https://scholar.google.com/citations?hl=es&user=5FsnuoYAAAAJ>